



Model FT2A Gas Mass Flow Meter & Temperature Transmitter

For Industrial, Environmental, Energy Monitoring and Process Control Applications

- Measures gas flow rate in SCFM, NM³/HR, LBS/HRr, KG/HR, & many more
- Wide measurement range; 100:1 turndown typical
- Measures process gas temperature
- 4 to 20mA for flow rate & temperature; pulse output for flow/total
- USB port to connect to a PC standard; RS485-Modbus, BACnet MS/TP, Profibus-DP, DeviceNet or Ethernet Modbus TCP
- Insertion and Inline models
- Welded, 316 SS sensor construction; Hastelloy C276 optional
- Microprocessor based, field programmable electronics
- On-board 2 line x 16 character, backlit display with configuration panel to view/set readings and parameters
- Free FT2A View™ Software available
- NIST traceable calibration
- Low-end sensitivity for leak detection
- Negligible pressure drop
- No moving parts design
- FM (U.S.) & FMc (CANADIAN) approved for Class I, II, III, Division 2, Groups A, B, C, D, E, F, G T4A hazardous locations. NEMA 4X and CE approved.



FM and FMc approved!

Theory of Operation

Fox Thermal Flow Meters use a constant temperature differential (constant ΔT) technology to measure mass flow rate of air and gases. The thermal mass flow sensor consists of two Resistance Temperature Detectors (RTD's). The sensor elements are constructed of a reference grade platinum wire wound around ceramic mandrels that are inserted into stainless steel or Hastelloy tubes.

The Reference RTD measures the gas temperature. The instrument electronics heat the mass flow sensor, or heated element, to a constant temperature differential (constant ΔT) above the gas temperature and measures the cooling effect of the gas flow. The electrical power required to maintain a constant temperature differential is directly proportional to the gas mass flow rate. The microprocessor linearizes this signal to deliver a linear 4 to 20 mA signal.

Fox Model FT2A Gas Mass Flow Meter & Temperature Transmitter

The Fox Model FT2A measures gas flow rate in standard units without the need for temperature or pressure compensation. It provides isolated 4 to 20 mA and pulse outputs for flow rate, and a 4 to 20 mA output for process gas temperature. The pulse output is normally used for totalization.

With an on-board 2 line x 16 character, backlit display, operators can view flow rate, total, elapsed time, process gas temperature, and alarms. The display is also used in conjunction with the Configuration Panel to configure flow meter settings, pulse output frequency scaling, pipe area, zero flow cutoff, flow filtering (damping), display configurations, diagnostics and high or low alarm limits.

The Model FT2A is available in both insertion and inline models. The insertion meter is easily installed by drilling a 3/4" hole in the pipe and welding on a 3/4" NPT coupling. A Fox-supplied compression fitting secures the probe in place. The inline model is available in 1/4-inch to 6-inch sizes and includes built-in flow conditioners that eliminate the need for long, straight pipe runs. The meter can be ordered with flange or NPT end connections.

Both models are supplied with 316 stainless steel wetted materials standard or Hastelloy C-276 as an option (inline flow bodies also available in carbon steel). A USB port to connect to a computer or laptop is standard; interface options include RS485-Modbus, BACnet MS/TP, Profibus-DP, DeviceNet or Ethernet Modbus TCP.

Fox has certified cleaning and bagging procedures for flow meters to be used in oxygen applications.



SPECIFICATIONS

Performance Specs

Flow Accuracy:

Inline meter: $\pm 1\%$ of reading $\pm 0.2\%$ of full scale. 8 diameters of straight, unobstructed pipe upstream and 4 downstream required.

Insertion meter: $\pm 1\%$ of reading $\pm 0.2\%$ of full scale. 15 diameters of straight, unobstructed pipe upstream and 10 downstream required

Flow Repeatability: $\pm 0.2\%$ of full scale

Flow Response Time: 0.9 seconds (one time constant)

Temperature Accuracy:

$\pm 1.8^\circ\text{F}$ ($\pm 1.0^\circ\text{C}$) over -40 to 250°F (-40 to 121°C);

$\pm 3.6^\circ\text{F}$ ($\pm 2.0^\circ\text{C}$) over 250 to 650°F (121 to 343°C). Minimum velocity 60 SFPM.

Operating Specs

Units of Measurement:

SCFM, SCFH, NMPS, NM3/M, NM3/H, NM3/D, NLPS, NLPM, NLPH, MCFD, MSCFD, SCFD, MMSCFD, MMSCFM, SMPS, SM3/H, LB/S, LB/M, LB/H, LB/D, KG/S, KG/M, KG/H, SLPM, SFPM, MT/H, SM3/M, SM3/D

Flow Rates for Insertion Flow Meters:

15 to 60,000 SFPM (0.07 to 280 NMPS) - Air at 70°F (20°C) & 1 ATM

Turndown: up to 1000:1; 100:1 typical

To determine if an insertion flow meter will operate properly, divide the maximum flow rate by the pipe area. The application is acceptable if the velocity is within the velocity range above.

| Typical Flow Ranges for Insertion Flow Meters | | |
|---|------------|---------------------|
| Pipe size | SCFM | NM ³ /hr |
| 1.5" (40mm) | 0 - 840 | 0 - 1,320 |
| 2" (50mm) | 0 - 1,400 | 0 - 2,200 |
| 3" (80mm) | 0 - 3,080 | 0 - 4,860 |
| 4" (100mm) | 0 - 5,300 | 0 - 8,360 |
| 6" (150mm) | 0 - 12,000 | 0 - 18,900 |
| 8" (200mm) | 0 - 20,800 | 0 - 32,800 |
| 12" (300mm) | 0 - 46,600 | 0 - 73,500 |

| Flow Ranges for Inline Flow Meters | | |
|------------------------------------|------------|---------------------|
| Size | SCFM | NM ³ /hr |
| 0.25" | 0 - 20 | 0 - 32 |
| 0.5" | 0 - 90 | 0 - 140 |
| 0.75" | 0 - 180 | 0 - 280 |
| 1" | 0 - 320 | 0 - 500 |
| 1.25" | 0 - 580 | 0 - 910 |
| 1.5" | 0 - 840 | 0 - 1,320 |
| 2" | 0 - 1,400 | 0 - 2,200 |
| 2.5" | 0 - 2,000 | 0 - 3,150 |
| 3" | 0 - 3,080 | 0 - 4,860 |
| 4" | 0 - 5,300 | 0 - 8,360 |
| 6" | 0 - 12,000 | 0 - 18,900 |

Note: Standard conditions of air at 70°F and one atmosphere. Consult factory for other gases and for flow ranges above and below those listed above.

Gas Pressure (maximum):

Insertion Flow Meter: 500 psig (34.5 barg)

Inline (1/4" through 6"):

NPT 500 psig (34.5 barg); 150# flange 230 psig (16 barg)

Check with factory for higher pressure options.

Note: Pressure ratings stated for temperature of 100°F (38°C).

Relative Humidity:

90% RH maximum; non-condensing

Temperature:

Std sensor: -40 to 250°F (-40 to 121°C)

HT Sensor: -40 to 650°F (-40 to 343°C)

Enclosure: DC Power: -40 to 158°F (-40 to 70°C)

AC power: -4 to 158°F (-20 to 70°C)

Note: Display dims below -4°F (-20°C); function returns once temperature rises again.

Remote sensor junction box ambient temperature: -40 to 212°F (-40 to 100°C)

Input Power (without the Anybus serial communication option):

24VDC $\pm 10\%$, 0.4 Amps (standard DC Power)

85 to 264VAC, 47-63Hz, 12 Watts (with AC power option)

Input Power (with Anybus serial communication option):

24VDC $\pm 10\%$, 0.7 Amps (standard DC Power)

85 to 264VAC, 47-63Hz, 20 Watts (with AC power option)

Outputs:

Two isolated 4 to 20mA outputs (one for flow rate & a second is programmable for flow rate or temperature); fault indication per NAMUR NE43.

Isolated pulse output 0 to 100Hz, 5 to 24 volts p/p for flow (the pulse output can be used as an isolated solid state output for alarms); 10mA max.

USB connector for connecting to a laptop or computer is standard; free PC-based software tool - FT2A View™ - provides complete configuration, remote process monitoring and data logging functions.

Optional isolated communication outputs: RS485-Modbus, BACnet MS/TP, Profibus-DP, DeviceNet or Ethernet Modbus TCP.

Physical Specs

Sensor Material:

316 stainless steel standard; Hastelloy C276 optional

Inline Flow Body Material:

316 Stainless Steel flow bodies standard; Optional A106 Grade B carbon steel flow bodies and A105 flanges.

Enclosure:

NEMA 4X, aluminum, dual conduit entries with 3/4" NPT or optional M20 x 1.5mm.

Cabling:

To Fox remote enclosure: 5-conductor, 18 AWG, twisted, shielded, 100 feet maximum.

Retractor Assemblies:

Packing gland assembly: 125 psig (8.6 barg) max.

High pressure (crank) retractor: NPT 600 psig (41.4 barg), ANSI 150 flange & ANSI 300 flange, no valve supplied.

Dimensional

Insertion Flow Meters: Probe diameter: 1/2"

Equation for selecting insertion flow meter probe length: Probe length = 1/2 pipe ID (in inches) + 2" + thickness of insulation (if any) + dimension of retractor (if supplied). Round up to the next standard probe length available.

Assuming there is no insulation or retractor, Fox recommends the following probe lengths:

| Pipe Size | Probe Length |
|---|--------------|
| 1.5" (40mm) to 2" (50mm) | 4-inch |
| 2.5" (65mm) to 6" (150mm) | 6-inch |
| 8" (200mm) to 12" (300mm) | 9-inch |
| 14" (350mm) to 18" (450mm) | 12-inch |
| Use the equation on previous page for larger pipe sizes | |

Probe Lengths (LL) in inches(cm) =
 4.0 (10.2) 6.0 (15.2) 9.0 (22.9)
 12.0 (30.5) 15.0 (38.1) 18.0 (45.7)
 24.0 (61.0) 30.0 (76.2) 36.0 (91.4)
 Contact Fox for longer probes.

| Inline Flow Meter Dimensions | | |
|------------------------------|-------------|-------------|
| Pipe size | L | HH |
| 0.25" | 5.80 (14.7) | 9.9 (25.1) |
| 0.5" | 12.0 (30.5) | 9.9 (25.1) |
| 0.75" | 12.0 (30.5) | 9.9 (25.1) |
| 1" | 12.0 (38.1) | 9.9 (25.1) |
| 1.25" | 12.0 (30.5) | 9.9 (25.1) |
| 1.5" | 12.0 (30.5) | 9.9 (25.1) |
| 2" | 12.0 (30.5) | 9.9 (25.1) |
| 2.5" | 18.0 (45.7) | 10.0 (25.4) |
| 3" | 18.0 (45.7) | 10.0 (25.4) |
| 4" | 18.0 (45.7) | 10.5 (26.7) |
| 6" | 24.0 (61.0) | 11.6 (29.5) |

Note: Dimensions are in inches (cm). For certified drawings, consult factory or view at www.foxthermalinstruments.com/visual-forum/all-dimensions.php

PRESSURE

Pressure Drop Charts for Inline Flow Meters

As seen in the charts below, pressure drop is negligible and energy losses are minimal.

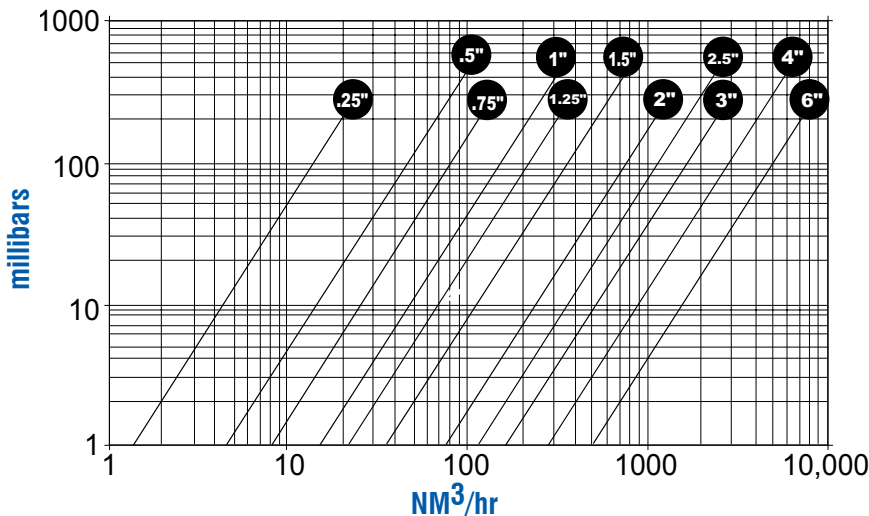
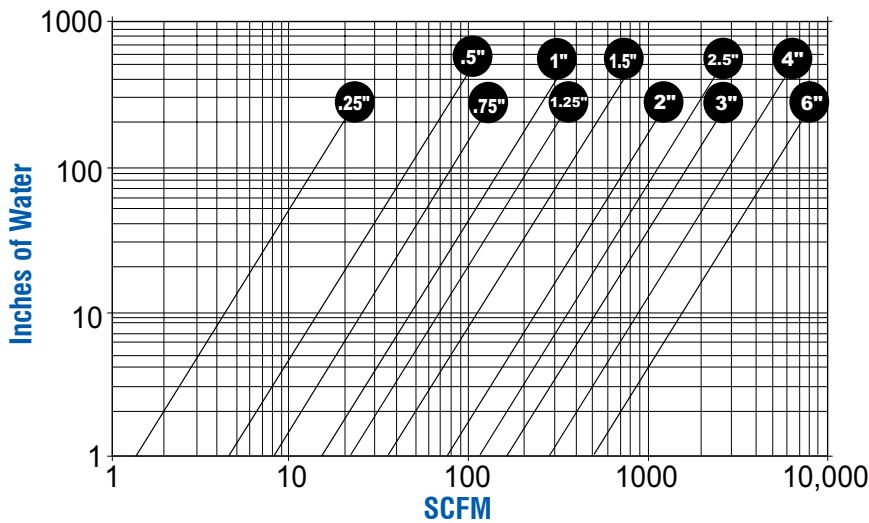

DIMENSIONS

Meter Dimensional Drawings

The FT2A is available in many different configurations. An example of the local insertion and remote inline flange configurations are shown below. To see more configurations, please visit our website at <http://www.foxthermalinstruments.com/visual-forum/all-dimensions.php>

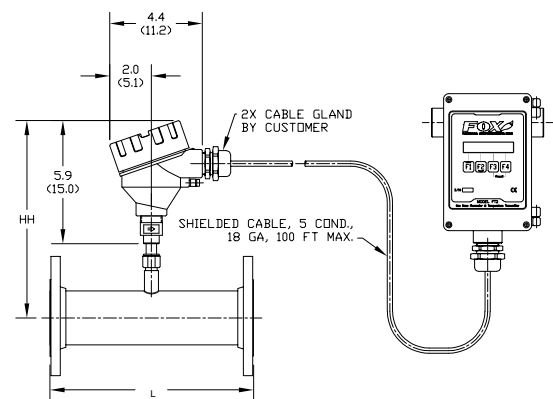
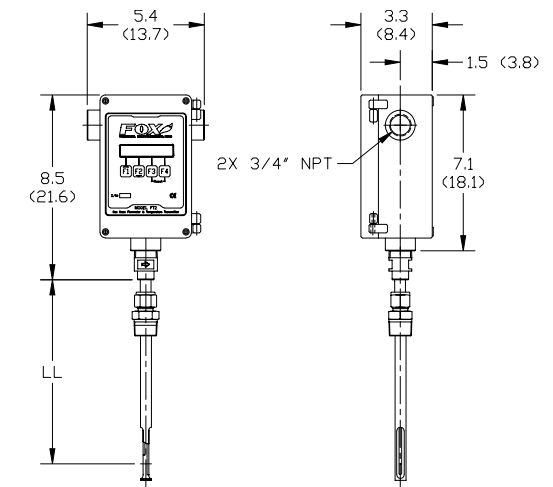

MODEL CODES

| Parent Model No.* | |
|---|---|
| FT2A | Thermal Mass Flow Meter & Temperature Transmitter |
| Feature 1A : Insertion Sensor* | |
| 06I | Insertion meter with 6-inch probe |
| 09I | Insertion meter with 9-inch probe |
| 12I | Insertion meter with 12-inch probe |
| 15I | Insertion meter with 15-inch probe |
| 18I | Insertion meter with 18-inch probe |
| 24I | Insertion meter with 24-inch probe |
| 30I | Insertion meter with 30-inch probe |
| 36I | Insertion meter with 36-inch probe |
| 15R | 15" Probe w/ 150 PSI retractor & full port valve - 3/4" male NPT, 316 SS wetted parts |
| 18R | 18" Probe w/ 150 PSI retractor & full port valve - 3/4" male NPT, 316 SS wetted parts |
| 24R | 24" Probe w/ 150 PSI retractor & full port valve - 3/4" male NPT, 316 SS wetted parts |
| 30R | 30" Probe w/ 150 PSI retractor & full port valve - 3/4" male NPT, 316 SS wetted parts |
| 36R | 36" Probe w/ 150 PSI retractor & full port valve - 3/4" male NPT, 316 SS wetted parts |
| R1 | Crank Retractor 1.5" NPT, 600 PSI, no valve - 316 SS wetted parts † |
| R2 | Crank Retractor 1.5", 150# flange, no valve - 316 SS wetted parts † |
| R3 | Crank Retractor 1.5", 300# flange, no valve - 316 SS wetted parts † |
| † Maximum pipe size is 1/2 the pipe diameter + valve dimension cannot exceed 19.5" | |
| Feature 1B : Inline Flow Body* (All available in 316 Stainless steel flowbody, **Available in A106 Grade B Carbon steel pip [+ A105 flanges - if ordered]) | |
| 025P | 1/4 inch, male npt ends (schedule 40) 5.8" Face-to-face |
| 05P | 1/2 inch, male npt ends (schedule 40) 12" Face-to-face |
| 075P | 3/4 inch, male npt ends (schedule 40) 12" Face-to-face |
| 10PS | 1 inch, male npt ends (schedule 40) 12" Face-to-face |
| 125P | 1.25 inch, male npt ends (schedule 40) 12" Face-to-face |
| 15P | 1.5 inch, male npt ends (schedule 40) 12" Face-to-face |
| 20P | 2 inch, male npt ends (schedule 40) 12" Face-to-face ** |
| 25P | 2.5 inch, male npt ends (schedule 40) 18" Face-to-face ** |
| 30P | 3 inch, male npt ends (schedule 40) 18" Face-to-face ** |
| 40P | 4 inch, male npt ends (schedule 40) 18" Face-to-face ** |
| 05F | 1/2 inch, 150# RF flanges (schedule 40) 18" Face-to-face |
| 075F | 3/4 inch, 150# RF flanges (schedule 40) 12" Face-to-face |
| 10F | 1 inch, 150# RF flanges (schedule 40) 12" Face-to-face |
| 125F | 1.25 inch, 150# RF flanges (schedule 40) 12" Face-to-face |
| 15F | 1.5 inch, 150# RF flanges (schedule 40) 12" Face-to-face |
| 20F | 2 inch, 150# RF flanges (schedule 40) 12" Face-to-face ** |
| 25F | 2.5 inch, 150# RF flanges (schedule 40) 18" Face-to-face ** |
| 30F | 3 inch, 150# RF flanges (schedule 40) 18" Face-to-face ** |
| 40F | 4 inch, 150# RF flanges (schedule 40) 18" Face-to-face ** |
| 60F | 6 inch, 150# RF flanges (schedule 40) 24" Face-to-face ** |
| Feature 2: Sensor Material* | |
| SS | Insertion: 316 stainless steel sensor and compression fitting; Inline: 316 stainless steel sensor and flowbody |
| SH | Insertion: Hastelloy C-276 sensor w/ 316SS compression fitting; Inline: Hastelloy C-276 sensor w/ 316SS flow body & compression fitting |
| SJ | Insertion: Hastelloy C-276 sensor and probe, Monel compression fitting; Inline: N/A |
| SL | Insertion: Hastelloy C-276 sensor and probe, Hastelloy C-276 compression fitting; Inline: N/A |
| Feature 3: Sensor Type* | |
| ST | Standard Sensor -40 to 250F (-40 to 121C) |
| HT | High Temperature Sensor -40 to 650F (-40 to 343C) E3 or E4, required - AIR ONLY |
| Feature 4: Enclosure and Power* | |
| E1 | Local NEMA 4X enclosure, 24VDC powered |
| E2 | Local NEMA 4X enclosure, 85 to 264VAC powered |
| E3 | Remote with explosion - proof sensor J-box, 24VDC powered, 100' max, no cable |
| E4 | Remote with explosion - proof sensor J-box, 85 to 264VAC power, 100' max, no cable |
| Feature 5: Bus Options* | |
| B0 | No communication bus |
| MB | Modbus (RS 485) |
| BN | BACnet MS/TP (RS 485) |
| BD | DeviceNet |
| BP | Profibus-DP |
| BE | Ethernet Modbus TCP |
| Feature 6: Gas Calibration* | |
| G1 | Air, N2: MF less than 1200 SCFM (2040 NM3H) |
| G2 | Air, N2: MF above 1200 SCFM (2040 NM3H) |
| G3 | Ar, CO2, H2, CH4, Natural Gas, O2: MF less than 1000 SCFM (1700 NM3H) |
| G4 | Ar, CO2, H2, CH4, Natural Gas, O2: MF above 1000 SCFM (1700 NM3H) |
| G5 | CO, He, Ammonia, Propane, Digester Gas: MF less than 700 SCFM (1190 NM3H) |
| G6 | CO, He, Ammonia, Propane, Digester Gas: MF above 700 SCFM (1190 NM3H) |
| G7 | All other gases |
| Optional | |
| NRT | Non Resettable Totalizer |

Adding an "E" after the probe code (i.e. 06IE, 18RE) will provide an equal length sensor. Equal length sensors can be used in pipes as small as 1.5" (40mm). Probes 04I and 15R are shipped standard with equal length sensors.



399 RESERVATION ROAD
 MARINA, CA 93933
 PHONE: 831-384-4300
 FAX: 831-337-5786
 sales@foxthermalinstruments.com
 www.foxthermalinstruments.com